

SIEMENS

System 777

Hi-Fi-Plattenspieler

pll quartz controlled direct
drive

RW 777 7/8



Bedienungsanleitung
Operating Instructions

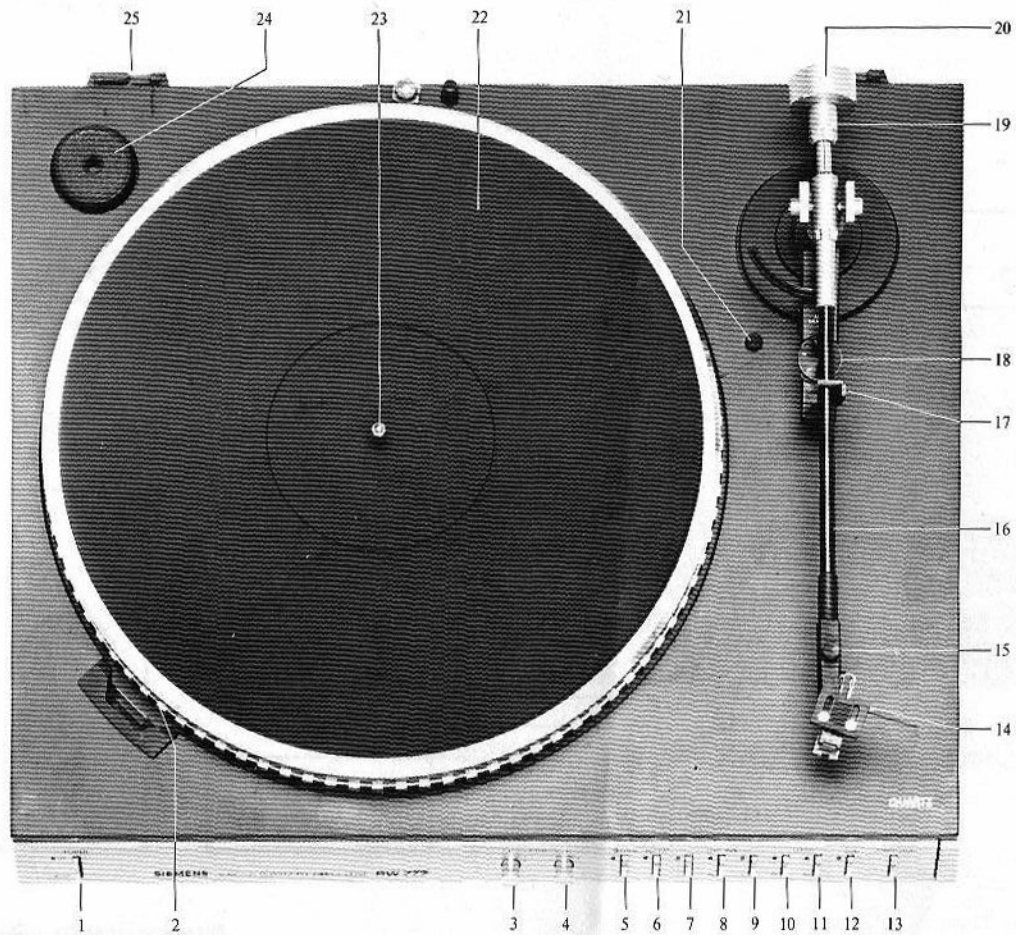

1	power	=	Ein/Aus
2		=	Stroboskop
3	pitch 45	=	Geschwindigkeits-Feineinstellung 45 U/min
4	pitch 33	=	Geschwindigkeits-Feineinstellung 33 U/min
5	quartz	=	Umschalttaste für Geschwindigkeitsregelung, bei Leuchtanzeige: quartzgesteuerte Geschwindigkeitsregelung; ohne Leuchtanzeige: manuelle Geschwindigkeitsregelung
6	repeat	=	Spielwiederholung ein/aus
7	disc size 17	=	Wahltaste für 17 cm Plattendurchmesser
8	disc size 25	=	Wahltaste für 25 cm Plattendurchmesser
9	disc size 30	=	Wahltaste für 30 cm Plattendurchmesser
10	speed 45	=	Geschwindigkeitswähler für 45 U/min
11	speed 33	=	Geschwindigkeitswähler für 33½ U/min
12	lift	=	Tonarmlift
13	start/stop	=	Start- und Stoptaste
14		=	Tonarmkopf mit System und Griff
15		=	Befestigung für Tonarmkopf
16		=	Tonarm
17		=	Tonarmstütze mit Verriegelung
18	antiskating	=	Einsteller für Antiskating
19		=	Kleines Tonarmgegengewicht mit Skala für Auflagekraft
20		=	Großes Tonarmgegengewicht
21		=	Justierschraube für Aufsetzpunkt
22		=	Plattenteller
23		=	Mittelachse
24		=	Adapter für Single-Platten 45 U/min mit großem Mittelloch
25		=	Scharnier für Abdeckhaube

Miscellaneous

Speed Check

The quartz-controlled pll circuit in your record player keeps the turntable speed constant and automatically corrects it should any deviations occur.

When the QUARTZ button (5) is depressed, the automatic speed control function is active and keeps the turntable speed at a constant $33\frac{1}{3}$ or 45 RPM. The indicator next to the button is lit and the PITCH speed vernier (3) and (4) are ineffective.

When the QUARTZ button (5) is not depressed (the indicator is not lit), the turntable speed can be modified with the PITCH vernier (3) for $33\frac{1}{3}$ RPM or the PITCH vernier (4) for 45 RPM. The speed setting is correct when the stroboscopic ring at the edge of the moving turntable, which is illuminated by the stroboscope (2), appears to be stationary. A requirement for this adjustment is a stable input power frequency.

Tone Arm Lift

The tone arm lift (12) allows the tone arm to be lifted off and lowered to any desired groove in the record particularly carefully, e.g. for briefly interrupting playback or for repeating or skipping specific passages.

The tone arm is lifted when you depress the LIFT button (12); the indicator next to it lights. When you depress the LIFT button again, the tone arm is lowered and the indicator goes dark.

If you have not used your record player for an extended period of time, it is possible that the oil-dampened tone arm lift will not work properly at first. In this case, move the lift up and down two or three times to activate the oil.

Playback Repetition

Should you want to play back a record repeatedly, depress the REPEAT button (6). The indicator next to it lights. Depress the REPEAT button again to end playback repetition.

Stylus Replacement

The diamond stylus is subjected to natural wear during playback. We therefore recommend you have it checked after about 300 hours of operation by a dealer who can also supply a new stylus „Audio Technical ATN 72 E“ for the model RW 777 7 or „Audio Technica ATN 30 E“ for the model RW 777 8. The stylus and its holder can be pulled out of the system in a downward direction.

Magnetic System Replacement

It is possible to install other systems with a weight of 4 to 10 grams in the head shell. To replace the system, apply the stylus cover, remove the two head shell screws, pull off the four leads and remove the system. After the insertion of the new system as shown below it may be necessary to readjust the overhang with the supplied gauge as shown the following illustration.

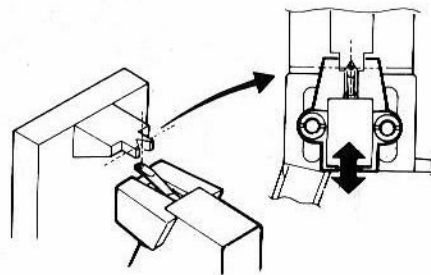
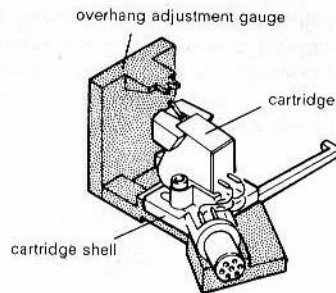

Application Point Adjustment

After system replacement it may be necessary to readjust the application point. To do this:

1. Check that the overhang and the antiskating feature are adjusted properly and that the system is fastened horizontally at the head shell;
2. Remove the cap covering screws (21);
3. Place a 30 cm diameter record on the turntable and depress button (1), (9), (11) and (13);

Aufstellmöglichkeiten
Arrangements

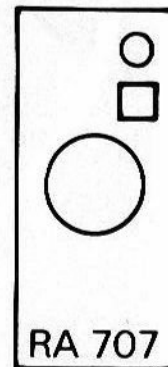
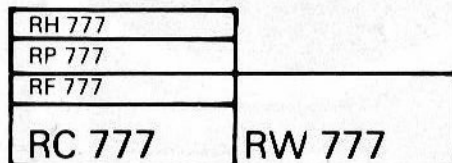
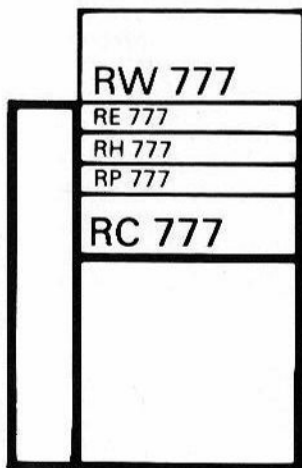
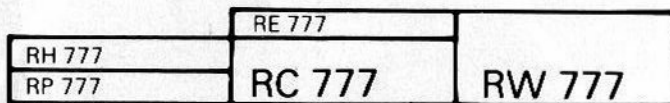
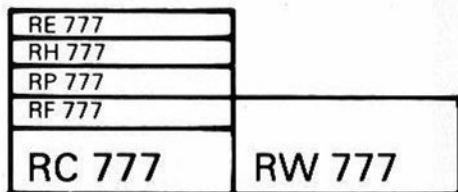

Bitte aufklappen
Please fold out



4. Turn adjustment screw (21) clockwise if the stylus is applied to the record too near the center or anticlockwise if it is applied too near the record edge. Do not turn more than + 15 degrees to avoid malfunctions.

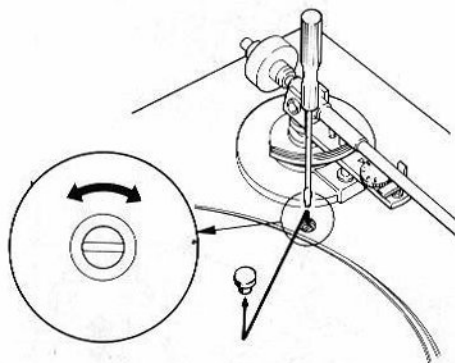

Technical Data

Turntable motor	20-pole dc motor with pll quartz control
Tone arm motor	2-pole collector motor
Drive	Direct
Turntable	Diameter 31 cm, weight 1500 grams
Speed check	Stroboscope
Speed regulation	± 2%
Speed deviations	Less than + 0.007%
Signal to rumble ratio, unweighted	Greater than 53 dB
Signal to rumble ratio	Greater than 73 dB
Input power	220 V ac, 50 to 50 Hz
Power draw	8 watts
Systems	Commercial systems with a weight of 4 to 8 grams and ½ inch mounting dimensions

Installed System

RW 7777

Moving-magnet system
Audio Technica AT 72 E

Stylus

Elliptic diamond
ATN 72 E .4 × .7

Stylus pressure

1 to 2 grams

Weight

5.5 grams

RW 7778

Moving-coil system
Audio Technica AT 30 E

Elliptic diamond
ATN 30 E .3 × .7

1.4 to 2 grams

5.0 grams

Modification without notice!

Hi-Fi Turntable RW 777 8

SIEMENS

tubifex.nl

Printed Circuits

Stromlauf · Abgleich · Bedruckte Platten
Schematic · Alignment · Printed Circuits

Schematic

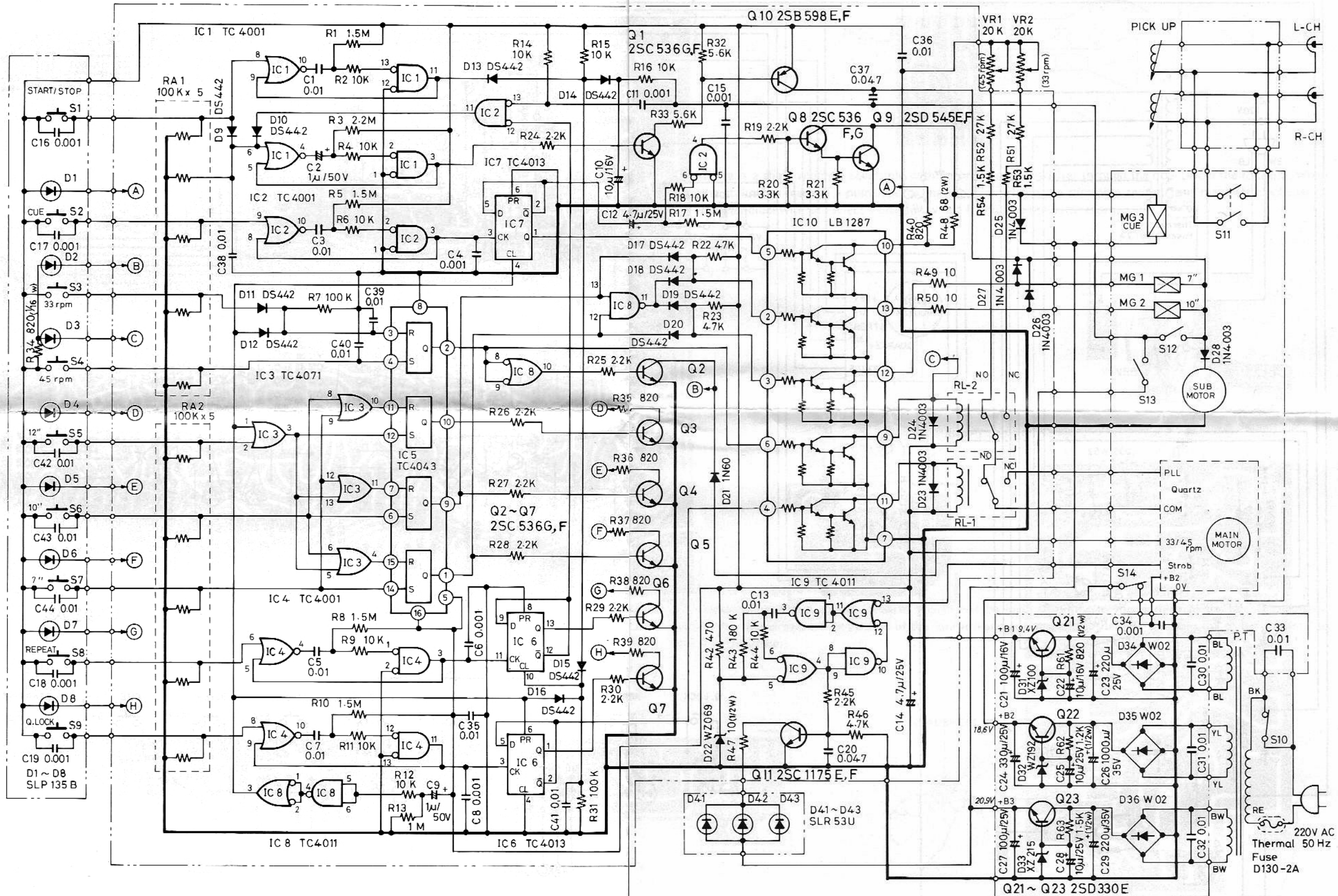

- | | |
|----------------------------|----------------------------|
| S1 ~ S9.....CONTROL SWITCH | S12.....STOP REMAIN SWITCH |
| S10.....POWER SWITCH | S13.....PLAY REMAIN SWITCH |
| S11.....MUTING SWITCH | S14.....PLAY SWITCH |

Alignments

AUTO-RETURN ADJUSTMENT

1. Adjust the stopper so that the shortest distance from the center of the center spindle to the lever is obtained 26.5 – 27.0mm.

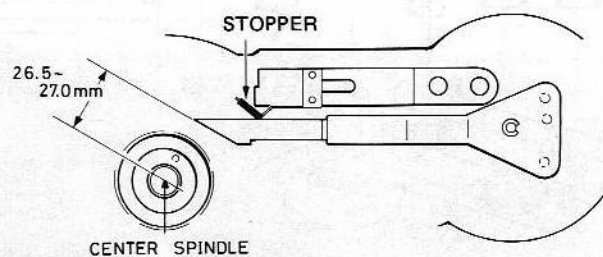

2. There is a shaft which is accessible with an ordinary screwdriver through the hole below the tonearm. When the stylus has reached a point approximately 55mm from the turntable center, turn the shaft clockwise or counter-clockwise and select a position where it actuates the auto-return.

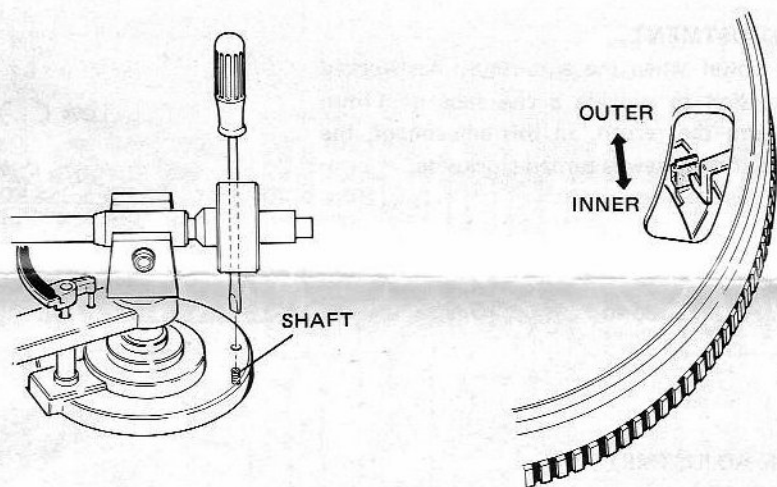

HEADSHELL ADJUSTMENT

The headshell attached to the tonearm should not be inclined either to the right or to the left. If necessary, loosen the two screws on the bottom of the tonearm and adjust the headshell. Be sure that the stylus is normal to the record surface.

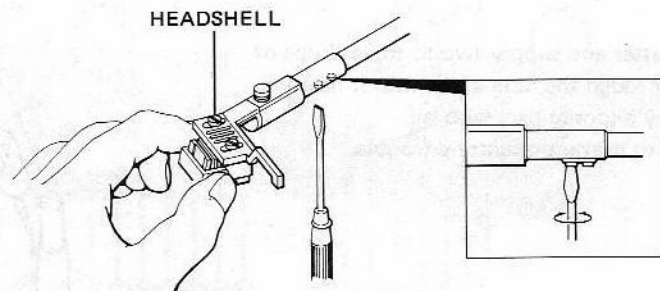

ONEARM LIFTER ADJUSTMENT

Push the cuing button, and turn the screw of the arm lifter to adjust so that the distance between the stylus and the record surface becomes 9mm when the stylus of the arm moves up near the outer circumference of the record.

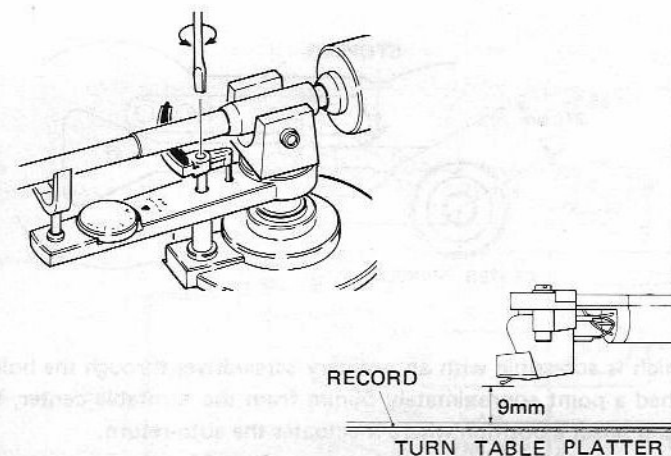

LIFT-UP LEVER ADJUSTMENT

Turn off the mains power when the auto-return has worked and adjust spring tension to provide a clearance of 11mm between the stylus and the record. In this adjustment, the lift-up lever will go up if the screw is turned clockwise.

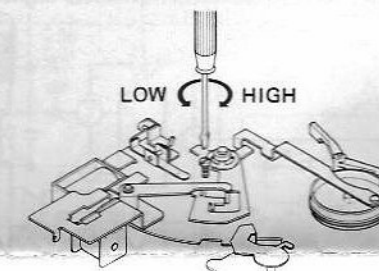

STYLUS SET DOWN ADJUSTMENT

Adjust the position of the stylus comes down in an auto play. Adjust the lever shaft so that the stylus comes down at the position of 147mm, apart from the center of a 12" record.

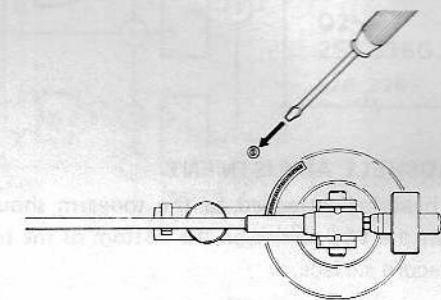

LUBRICATION

Remove the turntable platter and supply two to three drops of oil into the D.D. motor through the hole in the motor housing. Be careful not to stain any exposed part with oil. This caution is necessary to prevent operating trouble.

